

PAPER • OPEN ACCESS

Design of a Thick Gas Electron Multiplier based photon pre-amplifier

To cite this article: O. Putignano *et al* 2023 *JINST* **18** C06003

View the [article online](#) for updates and enhancements.

You may also like

- [Recent advances with THGEM detectors](#)
S Bressler, L Arazi, L Moleri et al.
- [Beam studies of novel THGEM-based potential sampling elements for Digital Hadron Calorimetry](#)
S Bressler, L Arazi, H Natal da Luz et al.
- [Towards THGEM UV-photon detectors for RICH: on single-photon detection efficiency in Ne/CH₄ and Ne/CF₄](#)
C D R Azevedo, M Cortesi, A V Lyashenko et al.

6TH INTERNATIONAL CONFERENCE FRONTIERS IN DIAGNOSTICS TECHNOLOGIES
ENEA FRASCATI RESEARCH CENTRE, FRASCATI, ITALY
19–21 OCTOBER 2022

Design of a Thick Gas Electron Multiplier based photon pre-amplifier

O. Putignano,^{a,b} A. Muraro,^{a,*} S. Cancelli,^{a,b} L. Giacomelli,^a G. Gorini,^{a,b} G. Grosso,^a
M.H. Kushoro,^{a,b} G. Marcer,^{a,b} M. Nocente,^{a,b} E. Perelli Cippo,^a M. Rebai,^a M. Tardocchi^a
and G. Croci^{a,b}

^a*Istituto per la Scienza e Tecnologia dei Plasmi-CNR,
via Roberto Cozzi, 53 20126 Milano, Italy*

^b*Dipartimento di Fisica, Università degli Studi di Milano-Bicocca,
Piazza della Scienza, 3 20126 Milano, Italy*

E-mail: andrea.muraro@istp.cnr.it

ABSTRACT: In this paper we present the design of a photon pre-amplifier based on a photo-cathode coated Thick Gas Electron Multiplier (THGEM). Such device is crucial in application where a weak light signal produced in a radiation detector must be amplified so that it can be carried to a photo-detector by means of optical fibres. An example of a device where a light signal must be amplified is a gamma-ray Cherenkov detector for fusion power measurements in magnetic confinement devices. In such application the active part of the detector must be located very close to the plasma, typically in a harsh radiation environment where standard photodetectors cannot operate. The photon pre-amplifier allows to increase the signal generated in the active part of the detector so that it can be easily detected by the photodetector located outside the harsh environment. We present the conceptual design of a THGEM based photon pre-amplifier supported by Garfield++ simulations. The device working principle is the following: primary photons impinge on the photo-cathode and extract electrons that are accelerated by the THGEM electric field. Upon collisions with the accelerated electrons, the gas molecules in the pre-amplifier are brought to excited states and de-excite emitting scintillation photons. Since each electron excites multiple gas molecules, the scintillation photons outnumber the primary photons, leading to the amplification. In addition, we present the first observation of measurements of Nitrogen gas scintillation in a THGEM device. We devised an experimental setup consisting of a vacuum chamber containing a THGEM and an alpha particle source. The vacuum chamber is filled with pure nitrogen and is coupled to a photomultiplier tube via

*Corresponding author.

a view-port to detect the scintillation photons generated in the THGEM. For sake of simplicity the electrons that induce the scintillation are generated by the ionization track of an alpha particle rather than by the THGEM photo-cathode coating. A good qualitative agreement between simulations and experiment has been found, however no quantitative conclusions can be made due to the lack of N_2 excitation cross sections in the Garfield++ code.

KEYWORDS: Cherenkov detectors; Nuclear instruments and methods for hot plasma diagnostics; Photon detectors for UV, visible and IR photons (gas)

Contents

1	Introduction	1
2	Thick Gas Electron Multiplier	1
3	Experimental setup	2
4	Garfield++ simulation	4
5	Results and outlook	4

1 Introduction

A radiation hard photon pre-amplifier may be integrated in different radiation detection devices. For example it is a crucial component of the 17 MeV gamma ray counter optimized to measure the fusion power in a magnetically confined plasma described in [1]. The photon pre-amplifier described in this work also acts as a wavelength shifter. It is composed of a CsI coated single THGEM (Thick Gas Electron Multiplier) working in pure nitrogen gas. The working principle of the photon pre-amplifier can be summarized in three steps:

- the primary photons extract electrons from a photo-cathode;
- the electrons are accelerated by an intense electric field and excite gas molecules on their paths;
- the gas molecules de-excite emitting secondary photons according to its excitation spectrum.

The *gain* G of this element is defined as

$$G = N_{\text{ph}}/N_i \quad (1.1)$$

where N_{ph} is the number of photon emerging from the pre-amplifier and N_i is the number of primary photons impinging on the pre-amplifier.

2 Thick Gas Electron Multiplier

The THGEM is a micro-pattern gas detector consisting of a 170 μm alumina slab coated on both sides with 15 μm thick gold electrodes [2]. The slab is pierced with 200 μm holes in an hexagonal pattern with pitch of 600 μm . In correspondence of the holes, an additional rim of 80 μm is etched from the electrode to avoid the formation of sparks between the top and bottom of the THGEM. A picture of the THGEM is shown in figure 1. When the conductors on the opposite faces of the foil are biased with a DC voltage, V_{GEM} , a very intense electric field is produced inside the holes [3]. Electrons that enter the holes are accelerated by the electric field and multiplied by ionizing collisions with the gas molecules.

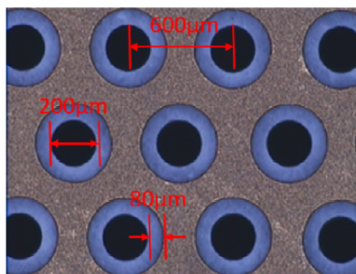

Figure 1. Microscope picture of the THGEM.

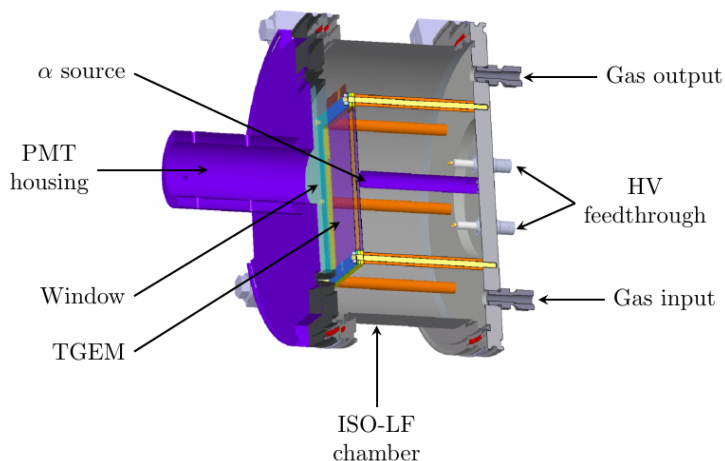

Figure 2. CAD drawing cross-section of the experimental setup.

Two additional fields are required when operating a standard THGEM: the *drift* field E_d , and the *induction* field E_i . The drift field guides the electrons created in the gas by ionizing radiation towards the THGEM foil. The drift volume is the active volume of a THGEM detector, i.e. the ionizing radiation that deposit charge in the region where the drift field is present are detected. The induction field extracts the electron from the THGEM foil.

3 Experimental setup

We built an experimental setup consisting of a vacuum chamber containing a THGEM detector and an alpha particle source. The scintillation light from the THGEM is measured by a Hamamatsu R9420-100-10-mod PMT. The vacuum chamber is composed by an ISO-LF200 full nipple closed by a flange at one end and a view-port at the other end. The flange has been machined to accommodate the gas and HV feed-troughs, the support for the THGEM detector, and the alpha source. A custom-made, light tight PMT holder was 3D-printed to hold the photomultiplier tube in place. A CAD drawing cross-section of the experimental setup is shown in figure 2.

The vacuum chamber is pumped down to a pressure of 2×10^{-2} mbar before being fluxed with atmospheric pressure nitrogen to minimize the impurity content in the setup.

In effect, the usage of the photocathode coating requires dedicated production and handling of the THGEM as CsI is hygroscopic and its performances are degraded if exposed to humidity present in ambient air. Moreover, the CsI coated THGEM would require a UV lamp to be inserted in the vacuum chamber to emulate the Cherenkov photons impinging on the photocathode. For sake of simplicity we decided to use an ^{241}Am alpha source, rather than the photocathode coating, to generate the primary electrons that induce N_2 scintillation in the THGEM.

Figure 3 shows a schematic drawing of the THGEM detector used in the experimental setup.

Alpha particles ionize nitrogen molecules in the gas producing electrons that are drifted towards the THGEM. Electrons are accelerated in the THGEM field where they induce the scintillation of nitrogen molecules. The scintillation photons are detected by the PMT. Alpha particles are emitted

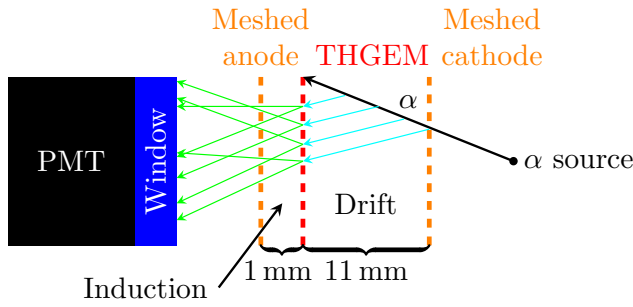

Figure 3. Schematic drawing of the THGEM assembly. The thin cyan arrows are electrons produced in the drift by the alpha particle and the thin green arrows are the scintillation photons.

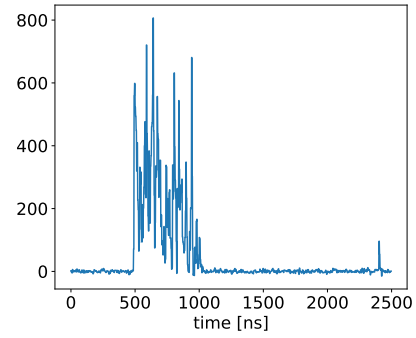

Figure 4. Scintillation in the THGEM recorded by the PMT.

by a ^{241}Am source, commonly employed in smoke detectors, placed inside the vacuum chamber. Alpha particles with energy of 5.486 MeV produced by the ^{241}Am source deposit $E_{\text{dep}} \approx 1.128$ MeV in the drift region, since the stopping power of nitrogen at atmospheric pressure is

$$\frac{dE}{dx} = 0.94 \text{ MeV cm}^{-1} \quad (3.1)$$

The ionization energy of nitrogen is $W_i(\text{N}_2) = 35$ eV, so the number of primary electrons, n_p , produced by the alpha particle in the drift region is

$$n_p = \frac{E_{\text{dep}}}{W_i(\text{N}_2)} \approx 34\,000 \quad (3.2)$$

Assuming that each primary electron produces at least one scintillation photon that reaches the PMT, we expect the light yield of the THGEM detector to be about the same as the one of a LaBr_3 detecting 500 keV gamma-rays.¹

The pulse width recorded by the PMT depends on the time needed by the electrons generated in the drift to reach the THGEM, on the lifetime of the N_2^* state, and on the PMT time response. Both the lifetime of the nitrogen excited states and the PMT response are of the order of the nanosecond [5, 6].

The drift field used in the experiment were in the order of 2 kV cm^{-1} ; the electron drift velocity for such fields in nitrogen, computed with the Magboltz code [7], is about $2 \text{ cm } \mu\text{s}^{-1}$. Thus, the signal length is dominated by the time needed for the electrons to cross the 11 mm long drift region and is around 500 ns.

Figure 4 shows a timetrace of the light emitted by the THGEM. The jagged profile of the waveform is due to the formation of electron clusters in the drift [8]. The electrons created in a cluster reach the THGEM at the same time, generating a strong scintillation light pulse. This feature indicates that the signals are generated by the alpha interacting in the drift indeed.

A series of measurements varying the THGEM bias voltage in the range 1 kV to 1.330 kV while keeping the drift and induction fields constant at 3 kV cm^{-1} and 2 kV cm^{-1} has been carried out to

¹The light yield of LaBr_3 scintillator is 63 photons/keV so 540 keV gamma-rays produce 34 000 photons in the scintillator [4].

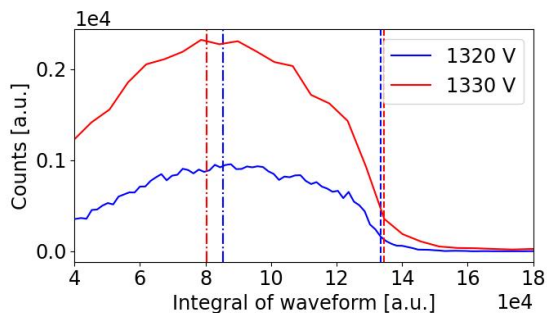

Figure 5. Pulse Width Spectrum for the THGEM biased at 1320 V (blue) and 1330 V (red). The dash-dotted lines are the mean value of the waveform integral histogram and are not representative of the full charge deposition in the drift volume. The dashed lines indicate the point where the histogram drops below 1/4 of the maximum value of the histogram, this point has been used to compute the gain as it is representative of the full charge deposition in the drift volume.

investigate the dependence of the number of photons produced in the THGEM on the applied voltage. Since the energy deposited in the drift by the alpha particles is widespread, the gain is defined as the point where the signal drops to 1/4 of the maximum of the Gaussian fit of the waveform integral histogram (see figure 5), this ensures that the maximum energy deposit is always taken into account when computing the gain.

4 Garfield++ simulation

The THGEM geometry was implemented in a Garfield++ simulation to simulate the photon gain of the pre-amplifier. The geometry of the simulation is depicted in figure 6. During the simulation, 100 000 primary electrons are created at the top of a THGEM hole, transported in the THGEM hole where they undergo collisions with the nitrogen molecules. Each time an inelastic, non-ionizing collision of the electron is recorded, a photon is simulated in a random direction. Garfield++ does not include the de-excitation cross-sections for nitrogen, so the simulation assumes that a photon is generated each time an inelastic collision happens. The number of photons reaching the window below the GEM is saved. The photon gain is calculated as the ratio between the number of photons reaching the window and the primary electrons in the simulation.

5 Results and outlook

The results of the measured and simulated THGEM bias voltage scan are compared in figure 7. With the current setup we cannot evaluate the absolute number of photons detected by the PMT. To be able to compare the simulation and measured gain we defined the relative gain as the ration between the gain obtained at voltage V and the gain obtained at 1 kV

$$G_r = \frac{G(V)}{G(1000\text{ V})} \quad (5.1)$$

The simulation qualitatively matches the experimental results, however no quantitative conclusions can be made due to the lack of the nitrogen photon emission cross-sections in Garfield++. Nonetheless,

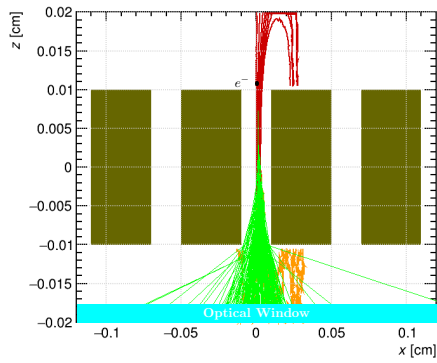

Figure 6. Garfield++ THGEM simulation.

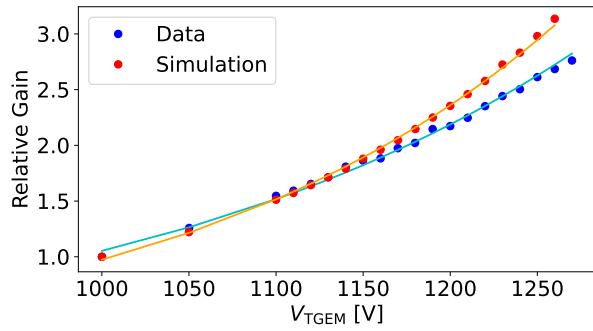

Figure 7. Experimental and simulated relative gain.

we observed nitrogen scintillation in a THGEM for the first time, demonstrating the basic working principle of the photon pre-amplifier.

We plan to modify the experimental setup to repeat the THGEM bias voltage scan in nitrogen at up to 2 bar, to investigate the gain dependence on the density of gas molecules that could allow higher THGEM bias voltage. Moreover, we plan to repeat the experiment using a CsI coated THGEM. To match the experimental results quantitatively we plan to include the nitrogen scintillation cross-sections in Garfield++.

References

- [1] O. Putignano et al., *Investigation of a Cherenkov-based gamma-ray diagnostic for measurement of 17 MeV gamma-rays from $T(D, \gamma)^5\text{He}$ in magnetic confinement fusion plasmas*, 2022 *JINST* **17** C02021.
- [2] J. Zhou et al., *A novel ceramic GEM used for neutron detection*, *Nucl. Eng. Technol.* **52** (2020) 1277.
- [3] M. Alexeev et al., *Status and progress of the novel photon detectors based on THGEM and hybrid MPGD architectures*, *Nucl. Instrum. Meth. A* **766** (2014) 133.
- [4] R. Sariyal, I. Mazumdar and S.M. Patel, *Measurement of absolute light yield and quantum efficiency of $\text{LaBr}_3:\text{Ce}$ scintillator detector using SiPM*, 2021 *JINST* **16** P12024.
- [5] M. Jeunehomme and A.B.F. Duncan, *Lifetime Measurements of Some Excited States of Nitrogen, Nitric Oxide, and Formaldehyde*, *J. Chem. Phys.* **41** (1964) 1692.
- [6] Hamamatsu r9420-100-10-mod pmt, https://www.hamamatsu.com/content/dam/hamamatsu-photonics/sites/documents/99_SALES_LIBRARY/etd/R9420_TPMH1296E.pdf.
- [7] Magboltz, <https://github.com/UTA-REST/MAGBOLTZdev>.
- [8] V.C. Antochi et al., *Combined readout of a triple-GEM detector*, 2018 *JINST* **13** P05001 [[arXiv:1803.06860](https://arxiv.org/abs/1803.06860)].